

各国における現場主義、グローバル・ローカリゼーションを実施しています



Portable Electronic AXLE LOAD SCALES



...Clearly a Better Value

Warranty - Five Years

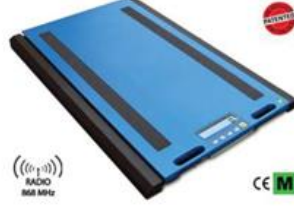
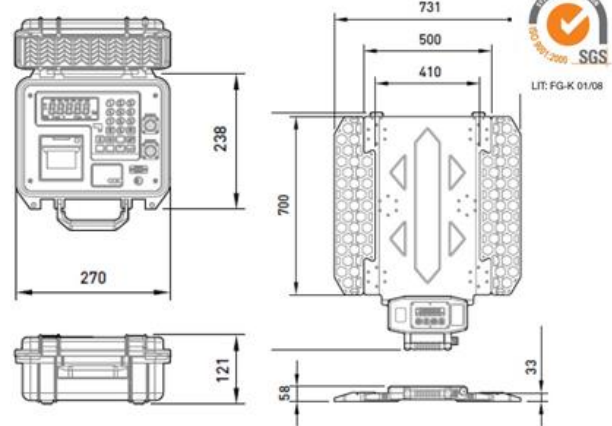

FEATURES

- High accuracy
- Portable
- By-Wheel Weight, Axle Weight or Total Weight
- Water proof IP 65(IEC 144)
- Advanced Digital Filtering to minimize vibration
- Test for axle balance & overload conditions

Searching for
a New Balance



Accessories : Ramps & Cable
Options : Dummy Plates

Wheel weighing system

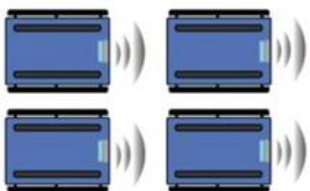

RADIO



JOHN SMITH LTD	
5TH AVENUE	
LONDON	
WWW.JOHNSMITH.COM	
WHEEL 1	1000 kg
WHEEL 2	1010 kg
WHEEL 3	1010 kg
WHEEL 4	1000 kg
GROSS=	4020 kg
TARE=	0 kg
NET=	4020 kg
10/05/2011	15:00



お問い合わせ

Designed for dependability and durability at a practical price!



Features

- Dual Range - 4 Capacities Available
- High resolution for accurate weighing/counting
- Simple and easy operation (9 large function keys)
- Counting & percentage mode
- Accumulation mode
- Weight/Count/Percentage comparison function (HI/OK/LO) with alarm beeps
- RS-232C interface (PC/Printer)
- Rechargeable battery
- Battery Saver w/Auto Power Off

- Backlight LCD
- Options: DLP-50 Label Printer
DEP-50 Receipt Printer
Dust Protection Cover
- Legal for Trade - COC # 09-072
* Counting feature not legal for trade



The ED Series is an advanced multifunction scale, from checkweighing to counting...

Specifications

Max. Capacity	1,000kg (2,000 lb)	5,000kg (10,000 lb)	10,000kg (20,000 lb)	15,000kg (30,000 lb)
Division	0.5kg (1 lb)	2kg (5 lb)	5kg (10 lb)	10kg (20 lb)
Accuracy	±1%			
Compensated Temperature	-10 °C ~ +40 °C			
Operating Temperature	-40 °C ~ +70 °C			
Size (L x W x H)	500 x 400 x 39mm (19.7" x 15.7" x 1.5")		900 x 500 x 39mm (35.4" x 19.7" x 1.5")	
Ramp	42 lb / 1.9 kg		14 lb / 6.4 kg	
Dummy plate			38 lb / 17.2 kg	
Product weight	35 lb / 15.8 kg		66 lb / 30.2 kg	
Shipping weight	65 lb / 29.4 kg		105 lb / 47.6 kg	

Display	LCD with Backlight
Display Designators	STABLE, ZERO, NET, SUM, LO, OK, HI, pcs, lb, oz, g, kg, %, LACK OF UNIT
Zero Range	+/- 2%
Tare Range	Full Capacity by Subtraction
Power	AC adapter DC 12V/1A or 12V/800mA
	Internal rechargeable sealed acid battery - 6V DC
Battery Life	170 hours (without backlight)
Product Size (inch/mm)	13(W) x 13.6(D) x 4.2(H) / 330(W) x 346(D) x 107(H)
Platter Size (inch/mm)	12(W) x 8.75(D) / 300(W) x 222(D)
Operating Temp	-10°C ~ 40°C / 14°F ~ 104°F
Product Weight	9.9 lbs/4.5 kg

Labels & Receipt Samples

DEP-50 Receipt Printer

Dimensions

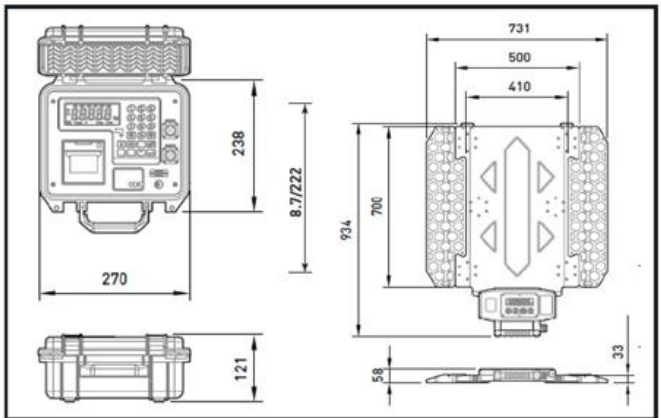

ROCK SOLID PERFORMANCE

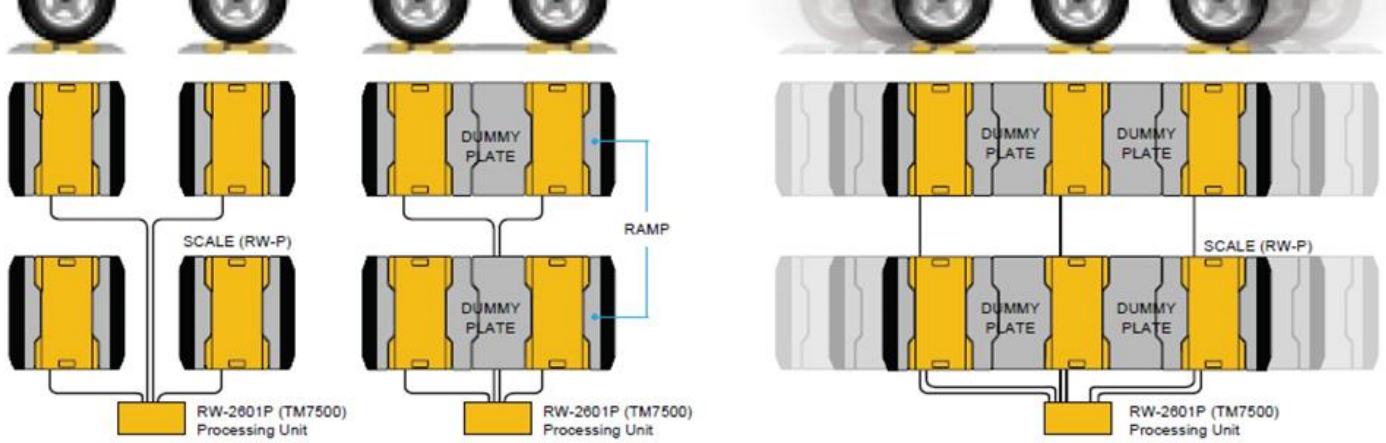

Projekt

Kunde:
 Fahrzeugtyp:

Datum:

3 Achs LKW mit Frontkran und Unterfald - Ladebordwand

Aufbauart:

Eingabe

Zul. Achslast Vorderachse: kg Zul. Achslast 1. Hinterachse: kg Zul. Achslast 2. Hinterachse: kg Zul. Gesamtgewicht: kg
 Fahrgestell leer Vorderachse: kg Fahrgestell leer Hinterachsen: kg Fahrgestell Leergewicht: kg
 Radstand von 1. - 2. Achse (WB1): mm Radstand von 2. - 3. Achse (WB2): mm Theoretischer Radstand (WBT): mm

Zusätzliche Gewichte

Fahrer: kg X1: mm
 Sonstiges: kg X1: mm

Frontkran

Palfinger PK 17502 Gewicht: kg
 Mitte VA bis Kranbeginn (Z): mm
 Breite des Krans (Y): mm
 Schwerpunkt des Krans (A1): mm

Ladebordwand

BÄR BC 2000H42 Gewicht: kg
 Schwerpunkt der Ladebordwand (A2): mm

Aufbau

Gewicht Aufbau/Nutzlast: kg
 Aufbaulänge außen (AL): mm

BERECHNEN

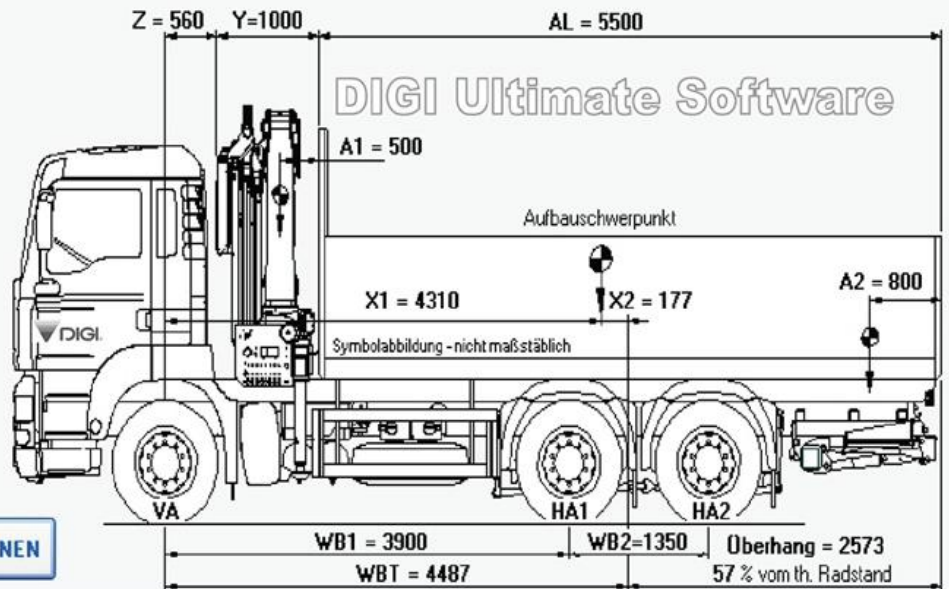

Ergebnis

Gewichte:	Gesamt		Vorderachse		Hinterachsen gesamt
Fahrgestell leer:	8575 kg		4810 kg		3765 kg
Fahrer:	75 kg	(X1 = 0 mm X2 = 4487 mm)	75 kg		0 kg
Sonstiges:	--- kg		--- kg		--- kg
Palfinger PK 175...	2450 kg	(X1 = 1060 mm X2 = 3427 mm)	1871 kg		579 kg
BÄR BC 2000H42:	635 kg	(X1 = 6260 mm X2 = -1773 mm)	-251 kg		886 kg
Aufbau/Nutzlast:	14265 kg	(X1 = 4310 mm X2 = 177 mm)	563 kg		13702 kg
Total:	26000 kg	100 % (max. 26000 kg)	7068 kg	94,2 % (mind. 6500 kg max. 7500 kg)	18932 kg
	0 kg Reserve		432 kg Reserve		4068 kg Reserve





"WEITRUCK": PC software for managing weigh bridges.

Software for a PC which allows to completely manage a weigh bridge system, combinable to the DFW and DGT series' weight indicators. Besides the complete management of the connected scale, the programme offers a simple and intuitive operator interface, wide range of supported functions, databases for the storage of the customer, material, and vehicle data, management of the totals and programmable printouts. Complete of alibi memory for approved systems.

MAIN FUNCTIONS

- Remote management of the weighing system, with display of all the scale status messages, selected storages, net, gross, and tare weights; execution of the ZERO, AUTOMATIC TARE, PRESET TARE, and PRINT functions.
- WEIGH MANAGED BY THE OPERATOR:
 - Single weigh, with entry of the vehicle tare weight.
 - INPUT/OUTPUT weigh, with recall of the input weigh through the vehicle plate or the weigh identifying code.
 - Customer, material and vehicle selectionable from database (over 5000 programmable storages) or with quick entry.
 - Completely programmable printouts, with graphic preview of the created format; the software allows also to create printouts with logos, barcodes, database date and all the weigh data under way.
 - Possibility of login with Smart Card, with management of various user groups (administrator, operator...).
- SELF SERVICE WEIGH:
 - This mode allows to use the weigh bridge without any operators, execution of the operations on PC, through the use of the BADGE or CHIP CARDS, directly programmable through the Weitruck, which contain the customer, material, and vehicle data.
- NOTE: along with the software also an alibi memory board will be supplied, to be installed on the weight indicator. This board also allows the functioning of the software and the approval of the system.



Wide range of connectable weight indicators.

SUPPORTED OPERATING SYSTEMS / MINIMUM SYSTEM REQUIREMENTS

- Windows XP professional SP2
- Pentium 3 1GHz or greater
- 256MB RAM
- At least 30MB of free space on disk
- Minimum display resolution of 800x600 (at least 65536 colours).



FEATURES

- Built-in clock & printer
- 1 Serial port: RS-232
- Built-in charger and batteries (DC 6V / 10AH x 2EA)
- High speed dot matrix receipt printer
- Connect to a PC or a Remote Display
- Connect up to 6 pads simultaneously
- Completely self-contained portable unit
- Large easy-to-read LCD display with back light
- Product Weight: 18.7lb/8.5kg

SPECIFICATIONS

Operating Power	Inner Battery Operation (DC6V/10AH x2EA)
Power Source	AC 110/220V, 50/60 Hz
Display Type	LCD with back light
Display Designators	Stable, Zero, kg/lb, bat
Product weight	9.2kg



...Clearly a Better Value

Panasonic Kenko Electric Co, Ltd
36 Sisenju, Okio, Osaka 234-23354 Japan
Tel. 81-32-565434667

Specifications subject to change without notice

